

GMO7 & GMO8 Gaussmeters

For Magnetic Measurements

Menu Driven/Selectable Units
(Tesla, Amp/m, Gauss, Oersteds)

Selectable Functions/Hand-Held

FEATURES

- Graphical LCD display
- USB & RS232 (GMO8)
- Menu Driven
- Multi lingual
- DC, AC, PEAK, MAX, HOLD and STORE functions
- Operating Function and Units displayed
- Analogue Output (GMO8)
- Thin semi-flexible probe
- Visible measurement point
- Probe polarity indication
- Battery operated
- External power supply connection (GMO8 only)



Hirst Magnetic Instruments GM07 and GM08 represents the second generation of microprocessor controlled Gaussmeters using the best of Digital Signal Processing (DSP) and Analogue Techniques to offer sophisticated measuring functions in a simple to use, menu driven, hand held package.

Designed for factory floor, on site and laboratory measurement of Magnetic flux Density and Magnetic Field Strength in SI or cgs, these instruments give excellent value for money.

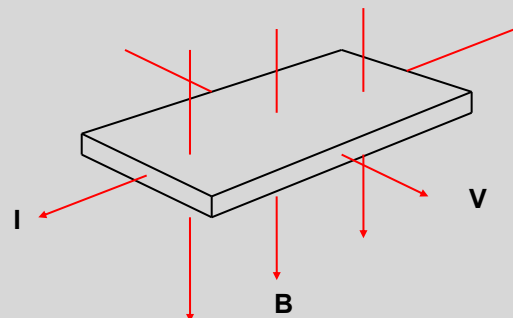

Measurement value Measurement units

Polarity

Measurement Function

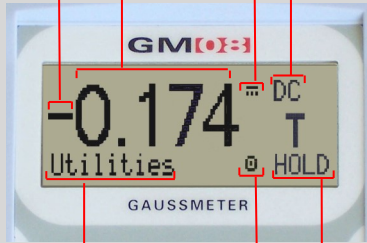

Menu option

Manual range

Display Status

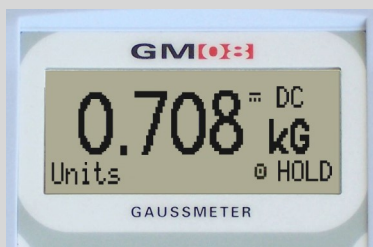
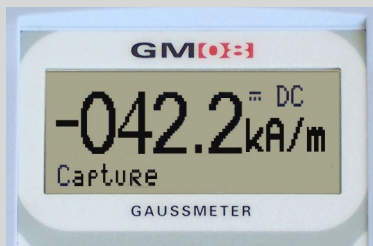
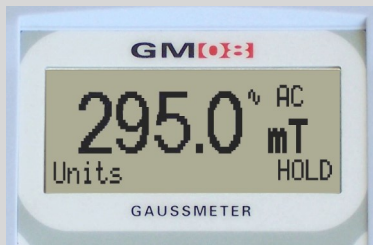
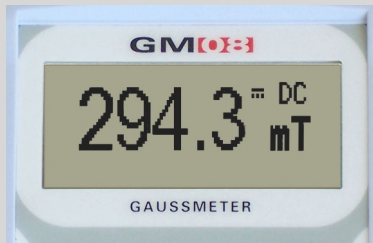

INTRODUCTION

The GMO7 and GMO8 Gaussmeters have been designed and manufactured by Hirst Magnetic Instruments Ltd. A company with more than 50 years experience in Magnetic Measurement. This experience together with our extensive knowledge of the magnetics market has enabled us to design an instrument incorporating all the measurement functions a user is likely to need. The GMO7/O8 is controlled via a simple menu and is supplied with a thin semi-flexible Transverse Hall Probe suitable for all but the very smallest applications.

FUNCTIONS

An easy to use menu enables you to change settings which are automatically stored when you switch off. On switch on it automatically remembers its previous setting.



Measurement functions

The GMO7/O8 can measure:

- DC DC magnetic field measurement
- DC PEAK Maximum positive peak reading of the DC field
- AC RMS True RMS (Root mean Square) of input signal
- AC MAX RMS Maximum true RMS (Root mean Square)
- AC PEAK Maximum positive peak reading of the AC field

Measurement Units

The GMO7/O8 can measure in Tesla, Amps/m, Gauss or Oersted. Saved readings can be automatically converted between measurement units.

Data captures

The GMO7/O8 can HOLD measured values by pressing the Hall Probe button. Pressing the button again releases HOLD (when enabled).

The GMO7/O8 can also STORE up to 100 measurements These values can later be RECALLED, either on the Gaussmeter or via USB/RS232 with the GMO8.

Utilities

The GMO7/O8 has a number of utilities options allowing the operator to disable or select various times for the automatic POWER DOWN. Nulling routines may also be selected.

The GMO7/O8 also has a facility to operate its menu structure in English, French, Spanish, Italian, German and Portuguese.

Display Status

When active, the status display is always in the top right hand corner, while the menu option display is in the bottom left hand corner.

COMMUNICATIONS

The GMO8 features an interface to provide USB communication, RS232 remote control of the GMO8 and the uploading of measurements and data.

The GMO7/O8 also incorporates a non volatile memory to enable the retention of stored values even when switched off and to retain instrument settings.

The GMO8 also includes a time keeping device to record the time data is stored and an external DC power supply socket for bench top applications.

SOFTWARE

Windows communication software is supplied with the GMO8. This allows the user to download readings, stored data and control the instrument remotely via USB or RS232 interfaces.

Data can be downloaded to Excel or open office spreadsheets, or to a CSV format file.

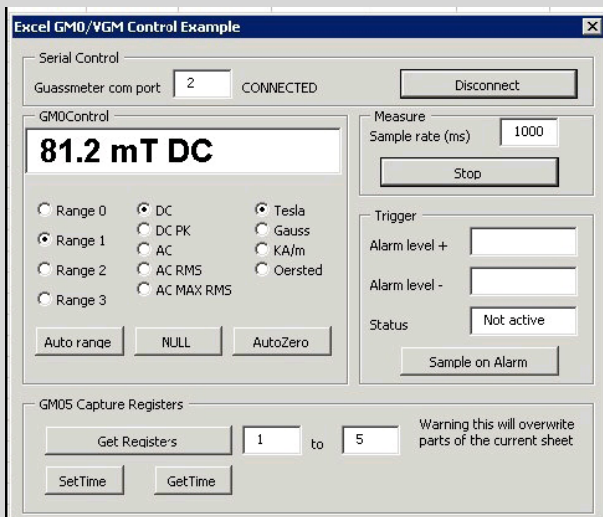

A full driver suite is available as an optional extra. This includes sample programmes with full source code (Microsoft Visual C++.NET) for the 2000 operating system, XP and later. A simple DLL allows third party integration of the GMO8 into embedded systems. A lab-view VI is included. Linux is also supported.

CALIBRATION

The GMO7/O8 is calibrated to standards traceable to the National Physical Laboratories (London UK).

During manufacture, the accuracy of nuclear magnetic resonance is used to determine the irregularities and non conformities of the GMO7/O8 and its Hall Probe. This is stored and used mathematically to automatically correct readings taken by the GMO7/O8.

APPLICATIONS

The GMO7 and the GMO8 are ideal for inspection and measurement of magnetic flux density of magnets and magnetic assemblies in both goods inward and Quality Assurance environments.

Where individual measurements need to be recorded the GMO8 will store and upload not only the measured values, polarity, measurement units and measurement function, but also the time at which the measurement was taken.

Applications include:

- Computer disk Drive Actuators,
- Loudspeaker Air Gaps
- Electric Motor air gaps
- Transformer Stray Field measurements
- Bending magnets
- Non destructive Testing (Magnetic)
- Goods inward and Quality Assurance Inspection
- Automated magnet calibration

PROBES

Both the GMO7 & the GMO8 are supplied with transverse hall probe (TP002) as standard .

TRANVERSE PROBES

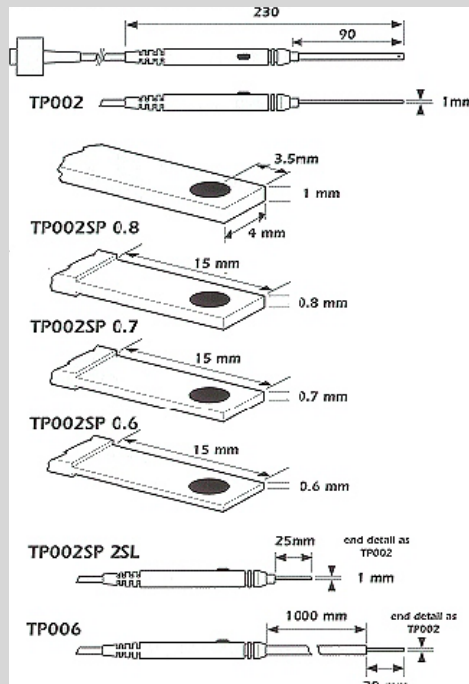

The probe is fitted with a push button enabling the operator to HOLD and STORE measurements and orientate the probe for polarity readings.

All transverse and axial probes are fully interchangeable with Hirst Magnetic Instruments Ltd's GMO4, GMO5, VGMO1, BGMO1, GMO7 & GMO8 gaussmeters.

Custom Axial and Transverse probes are also available. Please contact the sales office for more information.

AXIAL PROBES

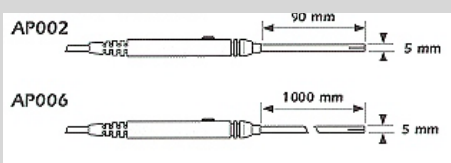

GMO7 & GMO8 SPECIFICATIONS

Model	GMO7 & GMO8	
Range 1	0.000 - ±3.000 Tesla	(00.00 - ±30.00 kiloGauss)
Range 2	000.0 - ±299.9 milliTesla	(0.000 - ±2.999 kiloGauss)
Range 3	00.00 - ±29.99 milliTesla	(000.0 - ±299.9 kiloGauss)
Range 4	00.00 - ±2.999 milliTesla	(00.00 - ±29.99 kiloGauss)
Frequency Range	DC and 15 Hz to 10 kHz	
Units	Tesla, Gauss, Amps/m or Oersted	
Functions	DC, DC peak, AC RMS, AC PEAK, AC MAX	
DC Accuracy	Better than ±1% Probe and Gaussmeter (NPL Traceable)	
Reproducibility	±0.5%	
Averaging time contact	100 milliseconds	
Display Sampling rate	3 readings per second	
Display	Dot Matrix Graphics LCD	
Memory type	Non-volatile	
Temperature coefficient	Better than ±0,1 % of reading/°C including probe	
Battery Type	4 x AA cells Longife 1,5V Alkaline	
Temperature: - Operating - Storage	0°C - 50°C 20°C - 70°C	(30°F + 125°F) (70°F + 150°F)
Dimensions: - Length: - Width; - Height:	175 mm 89 mm 40 mm	(6.9 in) (3.5 in) (1,6 in)
Weight: (not including probe)	430 g (15 oz)	

GM08 ADDITIONAL FEATURES

USB and RS232	Used for data transfer and remote control. Software handshaking. USB 1.1 Compliant
Analogue Output	+/-3 Volts full scale
Time keeping	Stored data is time stamped
External PSU Socket	Included - 5V/6V (100-500mA)
PC Software	Windows communication software

Hirst Magnetic Instruments Ltd. design a wide range of standard, special and custom magnetic instruments, equipment and turnkey systems including Integrating Fluxmeters, pulsed Field Magnetometers, VSMs Permeameters, Magnetisers, Demagnetisers, Calibrators and Magnetic Solenoids. www.hirst-magnetics.com for more information.

WHAT YOU GET



GMO8 inclusive package

- GMO8 Gaussmeter
- TP 002 Transverse Probe
- Zero Flux Chamber
- Instruction manual
- Calibration Certificate
- Hard plastic carrying case
- USB Lead
- RS232 Lead
- Analogue adaptor to allow BNC connections
- Software disk



GMO7 inclusive package

- GM07 Gaussmeter
- TP 002 Transverse Probe
- Zero Flux Chamber
- Instruction manual
- Calibration Certificate
- Hard plastic carrying case

OPTIONS

- Axial Probe AP002
- Other standard and custom probes
- Additional PC Software Disc (GMO8)